



Kevin P. Hengst,
 Architect

1250 Old River Road Suite 201 Cleveland Ohio 44113-1243 216 586 0440 f 216 325 0535 t

Job No. 21256

PET SUPPLIES PLUS
 Store #4175 Stony Point, NY
 Interior Renovation

22 Holt Dr. Suite 107,
 Stony Point, NY 10980

Details

A 8.1

1	2	3	4	5
D				
11	10	09	08	07
C				
06	05	04	03	02
B				
03	02	01	01	01
A				

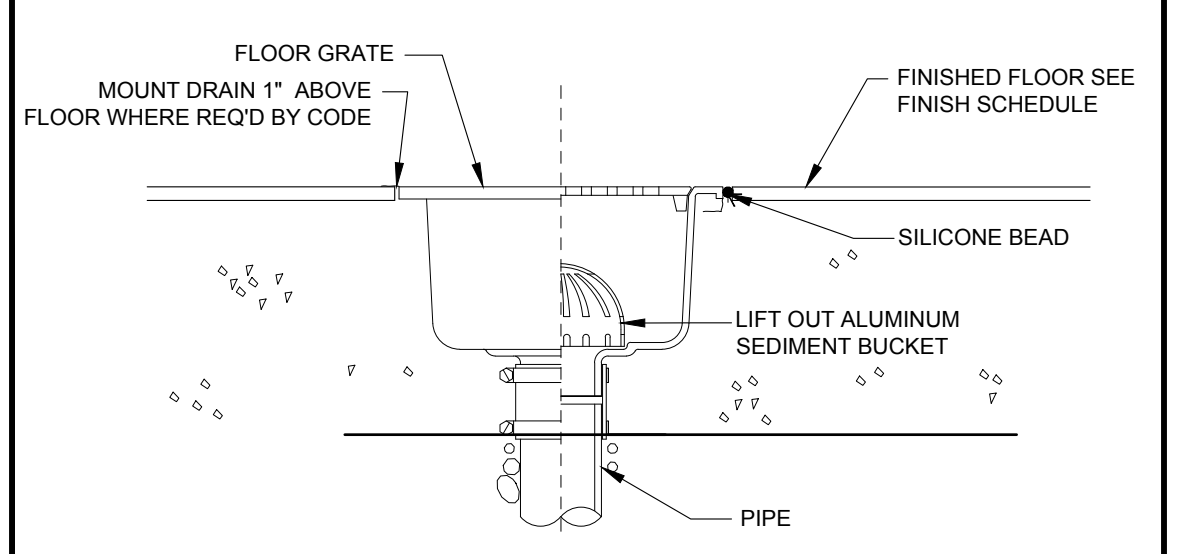
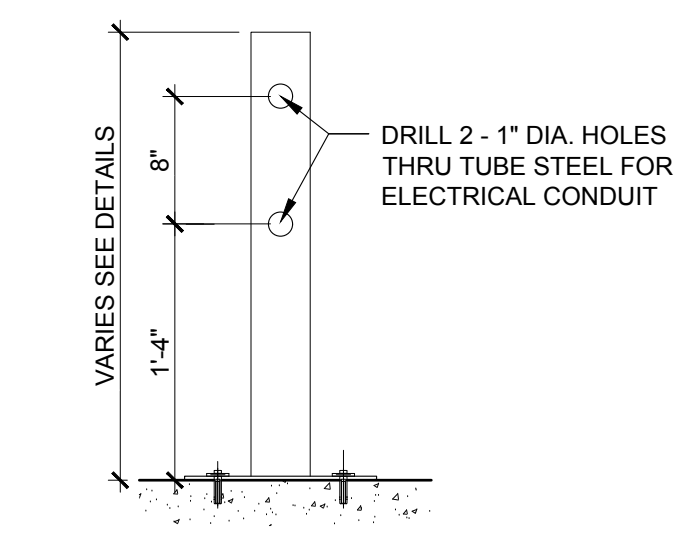
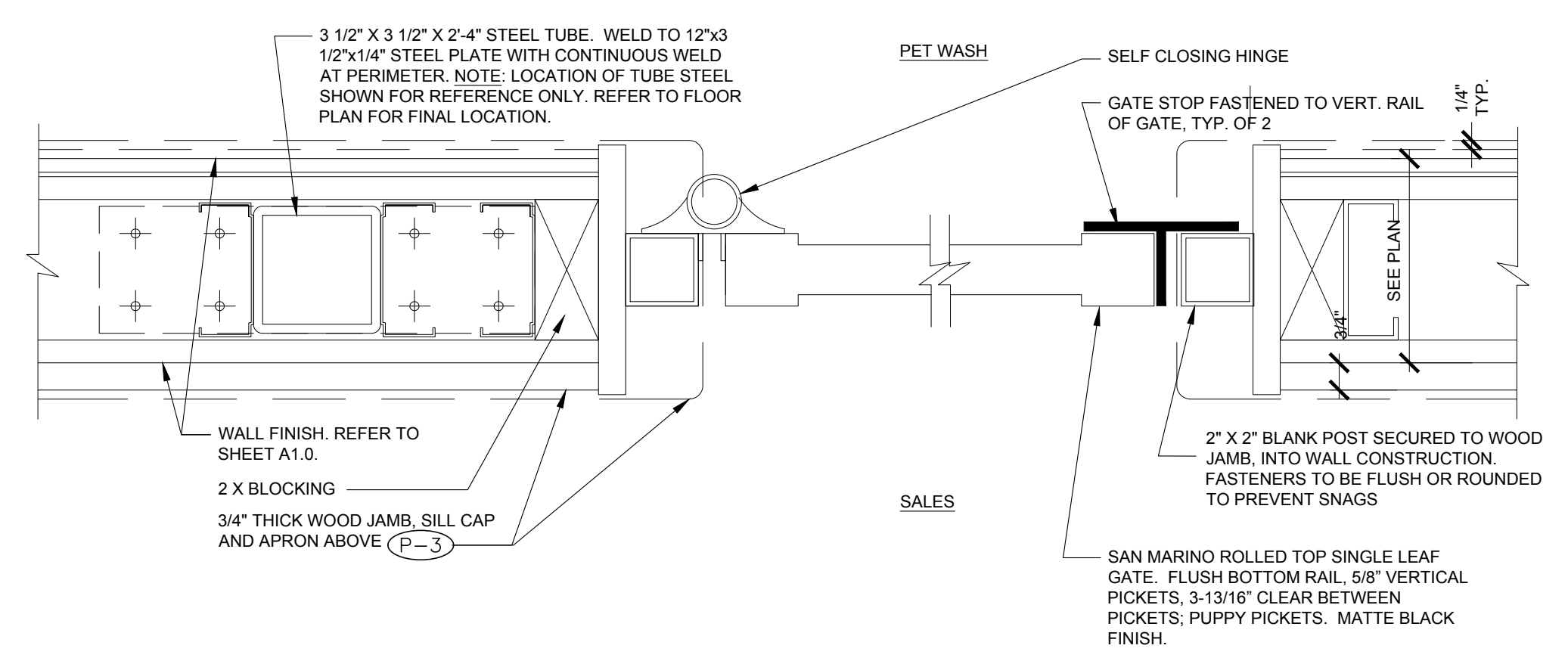
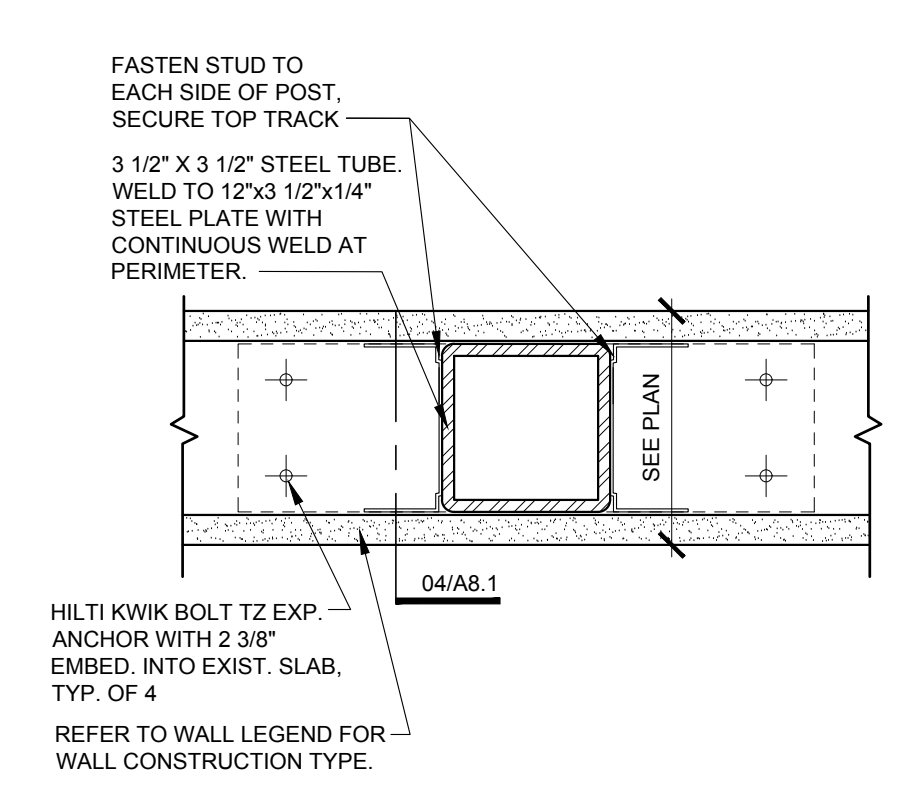

© Kevin P. Hengst, Architect. All rights reserved. No part of this document may be reproduced, stored in a retrieval system, or transmitted in any form or by any means, electronic, mechanical, photocopying, recording, or by any information storage and retrieval system, without the prior written permission of Kevin P. Hengst, Architect. This document is the property of Kevin P. Hengst, Architect and is loaned to you for your use only. It is not to be distributed, copied, or otherwise used without the express written permission of Kevin P. Hengst, Architect.